

BOSE

203 Loudspeaker

General Description

The Bose® 203 loudspeaker is a 100 Watt passively equalized loudspeaker designed for surface-mount installations in commercial spaces. It offers the following features:

- High fidelity sound reproduction from 60Hz to 16kHz
- Two patented 4.5" Bose StarDriver providing reliable, high quality sound in a compact enclosure
- One forward facing and one cross-firing driver to create a spacious soundstage over a broad listening area
- Internal protection circuitry
- Mounting hardware that permits fast and easy installation
- Elegant design available in professional grey and Arctic white can be painted to match any interior

Installation

All hardware and installation instructions are included with the loudspeakers.

The loudspeakers may be mounted horizontally using the mounting brackets, which attach to the internally-threaded inserts. The loudspeaker slips easily into the mounting bracket and can be moved left to right but not up or down for optimal visual and acoustic performance.

Accessory

The CVT-2 transformer is a multi-tap line transformer accessory that provides easy to change tap settings for 19W, 38W, 75W outputs (available for 70V and 100V applications). The transformer is designed specifically for use with the Bose 203 loudspeaker.

Warranty Information

All versions of the Bose 203 loudspeaker are covered by a 5-year, transferable limited warranty.

Technical Specifications

Frequency Range
60Hz to 16kHz, ± 3 dB

203 Versions

- 6 Ω , 100 Watt, (no transformer)
- 70V, 80 Watt, (transformer accessory)

Sensitivity¹

84dB-SPL, 1W, 1m

Maximum Acoustic Output²

104dB-SPL

Beamwidth (-6dB point)

Vertical: 132°

Horizontal: 185°

Long-Term Power Handling³

100W continuous

Dimensions

12.83"L x 8.43"D x 7.25"H

(32.6 cm (L) x 21.4 cm (D) x 18.42 cm (H)) enclosure

Weight

11 lb (5 kg)

Mounting Hardware

"Quick Install" bracket and hardware are included with each loudspeaker

Loudspeaker Configuration

The Bose® 203 loudspeaker can be used with the Bose AmPlus business music amplifier. It is also compatible with industry standard professional amplifiers. Because the loudspeaker is passively equalized, it does not require the use of an external equalization card.

The Bose 203 loudspeaker can be part of a distributed sound system when used in conjunction with the transformer accessory.

There are two loudspeakers per carton.

U.L. Certification

The Bose 203 loudspeaker meets all regulatory standards for surface-mount loudspeakers and are U.L. listed as vandal resistant.

¹Full bandwidth pink noise is amplified to a level at the loudspeaker terminals corresponding to 1 Watt as referenced to the nominal impedance. The average sound pressure level (dB-SPL) is measured at 1 meter from the speaker in an anechoic environment.

²Full bandwidth pink noise is amplified to a level at the loudspeaker terminals corresponding to the long-term rated power handling of the speaker. The average sound pressure level (dB-SPL) is measured at 1 meter from the speaker in an anechoic environment.

³Full bandwidth noise, meeting the International Electrotechnical Commission Standard #268-5 is amplified to a level at the loudspeaker terminals corresponding to the power handling of the loudspeaker. The loudspeaker must show no visible damage or measurable loss of performance after 100 hours of continuous testing.

Engineers' and Architects' Specifications

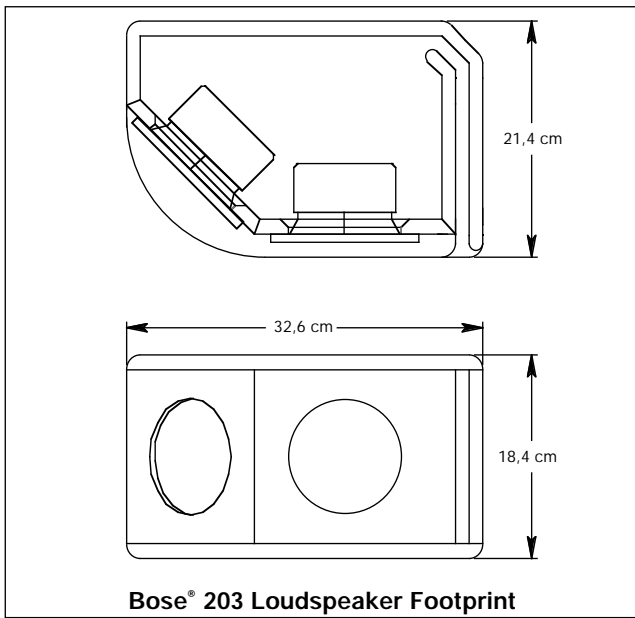

The loudspeaker shall be a 100 watt ported loudspeaker utilizing two 4.5 inch full-range drivers, one outward firing, and one cross-firing. The drivers shall have a rated impedance of 6 ohms nominal (4.8 ohm minimum). The loudspeaker is designed for direct connection to unequalized low impedance amplifier sources.

For 70 volts (100 volts) systems, an accessory transformer shall be used. The transformer shall offer 19, 38, and 75 Watt taps.

The loudspeaker shall have a maximum acoustic output of 104dB SPL from 60HZ -16kHz. The input connector shall be a barrier strip. The coverage angle shall be 132° vertical and 185° horizontal. The loudspeaker shall be available in professional grey and Arctic white. The loudspeaker shall be the Bose Model 203 loudspeaker.

Features, Functions, and Benefits for the Business Owner

Feature	Function	Benefit
Bose® quality sound technology.	High-fidelity, natural sound.	The Bose Model 203 professional loudspeaker is engineered from the ground up to provide natural, life-like sound in your business – the kind of sound that will set your establishment apart from your competitors'. Your customers have become used to quality sound in their homes and cars. They expect quality sound as well when they are out on the town. With the Bose 203 loudspeaker, you can be confident that your customers will enjoy quality sound whenever they visit your business.
Passive equalization.	Products that are cost effective and leverage existing investment.	The Bose Model 203 loudspeaker is a passively equalized loudspeaker – it does not require active equalization in the form of a system controller or amplifier plug-in card. It can be used with an existing amplifier.
Bose 4.5" StarDriver™.	Reliability.	One of the most critical parts of a loudspeaker is the transducer or driver. The Model 203 loudspeaker uses a proprietary Bose 4½ inch full-range driver. These drivers go through rigorous testing by Bose to ensure that they meet even the toughest requirements. As an indication of our confidence in the reliability of these loudspeakers they are covered by a five year transferable, limited warranty.
Virtually Invisible® loudspeakers.	Loudspeakers that will not interfere with the interior decor of the business.	The loudspeakers are small enough to blend in with the decor, rather than detracting from it. The Bose Model 203 loudspeaker is available in professional grey and Arctic white; also, it can be painted to match any decor.
Installation brackets.	Easy to install.	Fast, easy, cost-effective installation. Custom designed hardware is included for safe installation.